



*Deionized, Demineralized, or Reverse Osmosis Water*

# *“ECDDR” Series Electric Humidifier*

The “ECDDR” Series Electric Humidifier from PURE Humidifier Co. is loaded with features and options. All you need is deionized, demineralized, or reverse osmosis water, electricity, and a sanitary drain. The humidifier does the rest.

These units are designed to operate with absolutely pure water, which is corrosive and will not conduct electricity. They feature special stainless steel construction with special assembly techniques to ensure corrosion-resistant joints.

The water level is maintained with a special float valve to control the water level (instead of the Tri-Probe electronic water level controller that is utilized on the “EC” Series). A low water cut-off switch is utilized to protect the heating elements. Both floats are protected from water turbulence by an internal baffle. Since the reservoir’s water level is automatically and constantly adjusted, there is no downtime; steam is always available. A self-contained control panel with an electronic controller mounted within constantly monitors the humidifier cycle for efficient operation. The electronic controller also provides LED indicators to indicate the status of the humidifier. High efficiency immersion water heaters heat the water to provide steam.

All this is contained within an aesthetically pleasing cabinet that is constructed of 18-gauge steel with a baked enamel paint finish. The cabinet floor is designed as a drain pan with plumbing connections

for drain piping. The cabinet is designed to be compact for easy installation and maintenance. The internal stainless steel evaporating chamber is mounted on slides for easy removal. The electrical compartment is isolated from the evaporating chamber and is supplied with a key locked door.

When it comes to installation, you have a choice with the “ECDDR” Series Electric Humidifier. The humidifier can be wall mounted with a simple flexible hose connecting the unit to the stainless steel injection tube inserted through the duct wall. You can also mount the unit on the wall with the optional Blower Pack for direct room humidification. The Blower Pack can be mounted directly on top of the “ECDDR” humidifier or remote mounted, and contains a whisper-quiet adjustable speed fan to disperse the steam directly into the space without the use of ductwork.

Insty-Pac or Fast-Pac dispersion grids can be provided to custom fit any built-up or manufactured air handling system.

The versatility of the “ECDDR” Series Electric Humidifier will allow you to design them into any system simply, efficiently, and reliably. Capacities range up to 102 lbs/hr.

<b>ECDDR-5</b>	<b>ECDDR-10</b>	<b>ECDDR-15</b>	<b>ECDDR-20</b>	<b>ECDDR-25</b>	<b>ECDDR-35</b>
<b>15 lbs/hr (6.8 kg/hr)</b>	<b>30 lbs/hr (13.6 kg/hr)</b>	<b>45 lbs/hr (20.4 kg/hr)</b>	<b>60 lbs/hr (27.2 kg/hr)</b>	<b>75 lbs/hr (34.0 kg/hr)</b>	<b>102 lbs/hr (46.3 kg/hr)</b>

*Our results are comforting*



## Capacities & Piping Electrical Specifications

Sheet No.  
**ECDDR-2**

### Capacity & Weights “ECDDR” Series

Deionized Water Unit Model No.	Steam Output Capacity †		Humidifier Weight			
	lbs/hr	kg/hr	Empty		Full	
			lbs	kg	lbs	kg
ECDDR-5	15.0	6.8	139.0	63.1	223.0	101.2
ECDDR-10	30.0	13.6	140.0	63.5	224.0	101.6
ECDDR-15	45.0	20.4	141.0	64.0	225.0	102.1
ECDDR-20	60.0	27.2	142.0	64.4	226.0	102.5
ECDDR-25	75.0	34.0	143.0	64.9	227.0	103.0
ECDDR-35	102.0	46.3	146.0	66.2	230.0	104.3

### Electrical Specifications “ECDDR” Series

Deionized Water Unit Model No.	KW	No. of Heaters	Single Phase Amperage					Three Phase Amperage				Control Circuit Voltage		
			120V	208V	240V	480V	600V	No. of Heaters	208V	240V	480V		600V	
ECDDR-5	5	Single	41.7*	24.0	20.8	10.4	8.3	Triple	13.9	12.0	6.0	4.8	24 vac	
ECDDR-10	10	Double			41.7	20.8	16.7	Triple	27.8	24.1	12.0	9.6	24 vac	
ECDDR-15	15	Triple				31.3	25.0	Triple	41.7	36.1	18.1	14.4	24 vac	
ECDDR-20	20	Triple					41.7	33.3	Triple		24.1	19.2	24 vac	
ECDDR-25	25	Triple						41.7	Triple			30.1	24.1	24 vac
ECDDR-35	34	Triple							Triple			40.9	32.7	24 vac

\* ECDDR-5 at 120/1 requires 3 heating elements.

† The above capacities are based on 100% efficiency. Actual humidifier capacity may vary due to the heat loss from the humidifier reservoir. The ambient air temperature, air velocity, and injection tube system will affect the rate of heat loss from the humidifier reservoir.

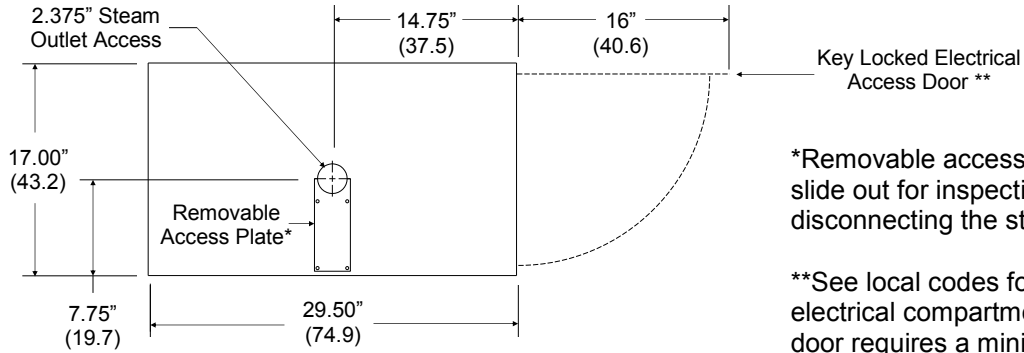

**TOP VIEW**

\*Removable access plate allows reservoir to slide out for inspection and cleaning without disconnecting the steam supply piping.

\*\*See local codes for minimum clearance to electrical compartment. The electrical access door requires a minimum clearance of 16" to fully open.

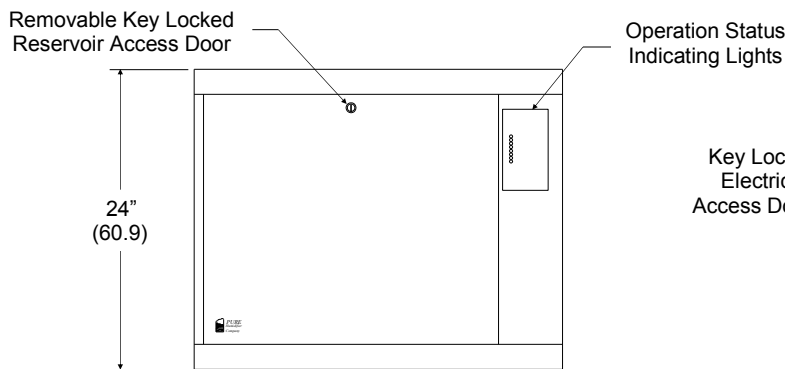

**FRONT VIEW**

**RIGHT SIDE VIEW**

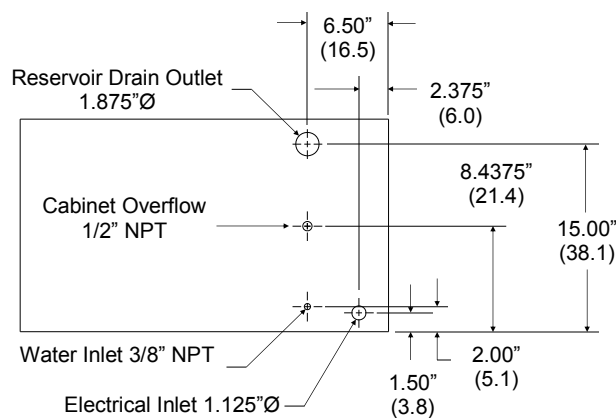

**BOTTOM VIEW**

Note: Dimensions are typical for all ECDDR models.

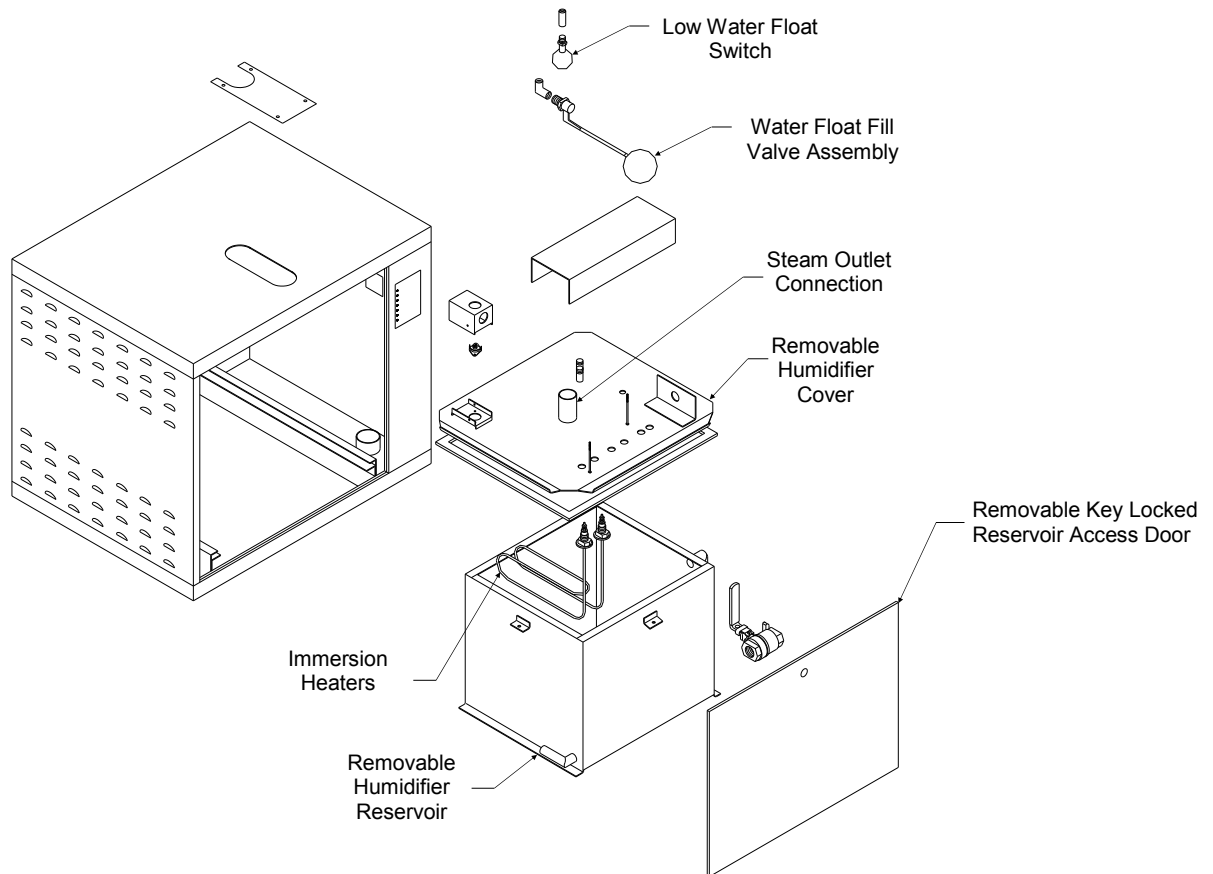

### Humidifier Features

- SCR modulating control
- Visible status and diagnostic LED indicator lights
- High-efficiency incoloy immersion water heaters
- 18-gauge steel cabinet with baked enamel paint finish
- Internal stainless steel evaporating reservoir mounted on slides for easy removal
- Key locked doors for both reservoir and electrical access
- Easy and simple installation options
- Dispersion methods include Insty-Pac\*, Fast-Pac\*, Injection Tube with Flexible Hose\*, or Blower Pack assembly\* for room distribution
- Manual reset over-temperature safety switch
- INTAC® microprocessor control system\*
- VAV dual modulating control system\*

\* Optional features

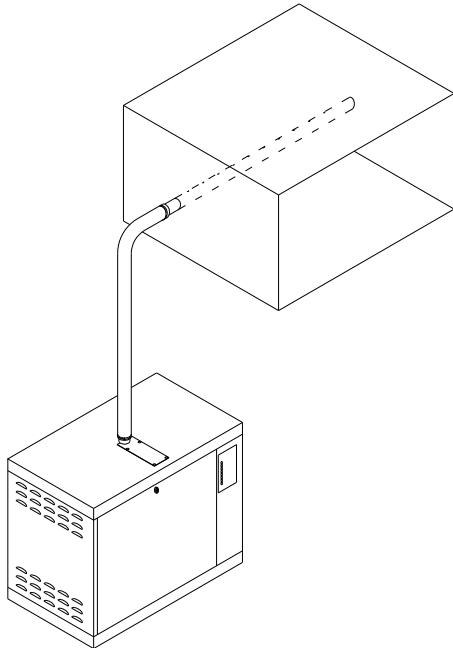

**Injection Tube and Flexible Hose**

Allows remote mounting of the humidifier reservoir from the duct. Also allows the humidifier to be located below a wall-mounted duct.

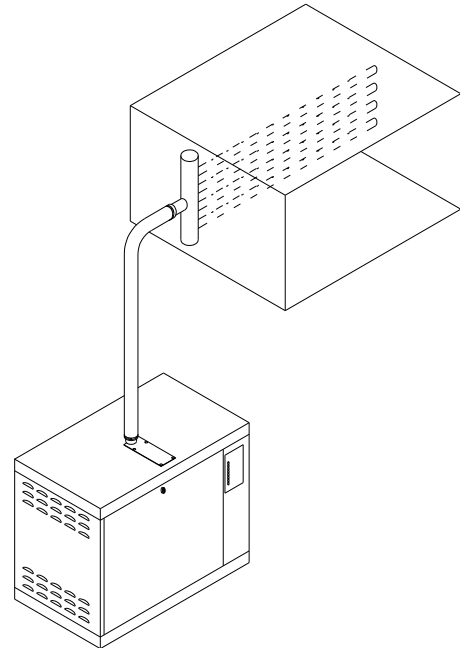

**Insty-Pac and Fast-Pac  
 Multiple Injection Tube Assemblies**

For applications where you need a short dissipation distance. Allows remote mounting of the humidifier reservoir from the duct. Also allows the humidifier to be located below a wall-mounted duct.

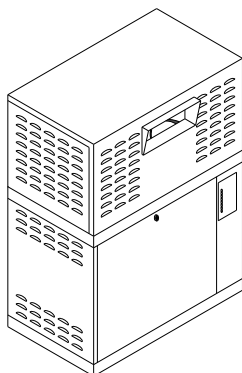

**Blower Pack for Direct Room Humidification**

Allows humidifier to be mounted directly on the wall within the space to be humidified.

**Optional Blower Pack**

In applications where a ducted air system is not available, PURE offers the optional Blower Pack. The Blower Pack contains a two-speed adjustable blower that moves the air over the steam discharge outlet and disperses the steam directly into the space (see Fig. 1). The Blower Pack mounts directly on top of the "ECDDR" humidifier or can be mounted remotely (see Fig. 2).

**Locating Blower Pack**

The distance that visible steam will travel after leaving the Blower Pack is dependent upon the relative humidity in the room and the capacity of the humidifier. If this visible steam comes in contact with any solid object (walls, beams, machinery, etc.) it may form condensate and drip. Refer to Fig. 3 and Table 4 (Table 4 is located on page ECDDR-7) for data on visible steam travel. This will aid you in planning the location of the Blower Pack.

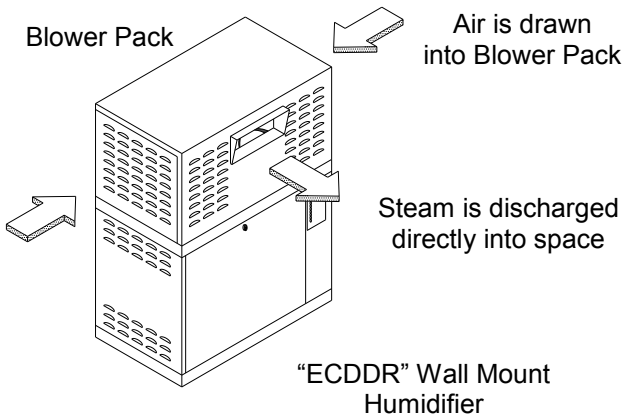

**Remote Mounting**

The Blower Pack may be remote mounted up to ten feet away from the "ECDDR" wall mount humidifier (see Fig. 2).

**"ECDDR" With Optional Blower Pack**  
**Fig. 1**

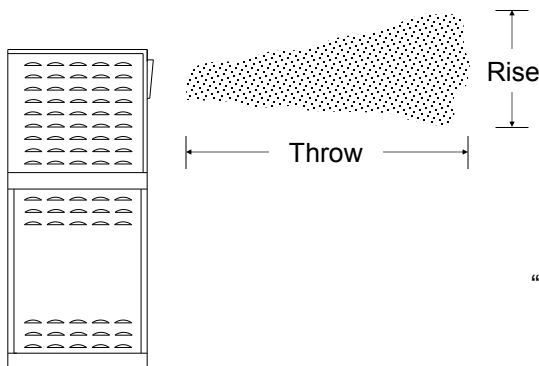

**Visible Rise and Throw**  
**Fig. 3**

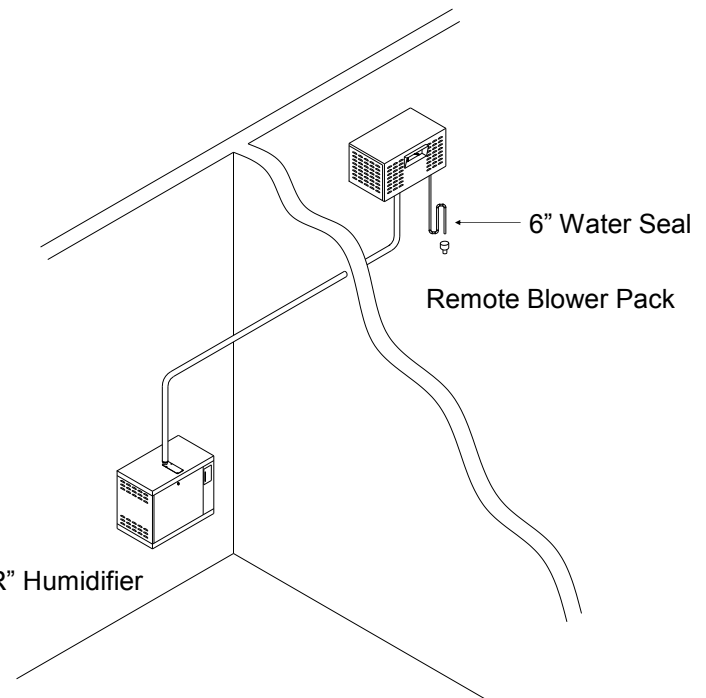

**Remote Mounted Blower Pack**  
**Fig. 2**

### Locating Blower Pack

The distance that visible steam will travel after leaving the Blower Pack is dependent upon the relative humidity in the room and the capacity of the humidifier. If this visible steam comes in contact with any solid object (walls, beams, machinery, etc.) it may form condensate and drip. Refer to Fig. 3 (Fig. 3 is located on page ECDDR-6) and Table 4 for data on visible steam travel. This will aid you in planning the location of the Blower Pack.

**Table 4**

Visible Steam Rise & Throw		Humidifier Model					
		ECDDR-5	ECDDR-10	ECDDR-15	ECDDR-20	ECDDR-25	ECDDR-35
<b>50% RH</b>	Rise (ft)	1'	2'	3'	4'	5.5'	8'
	Throw (ft)	8'	10'	13'	16'	18'	23'
<b>60% RH</b>	Rise (ft)	2'	3'	4'	5'	6'	8'
	Throw (ft)	13'	14'	16'	18'	20'	25'

**Throw** is the horizontal distance the visible steam travels from the steam discharge.  
**Rise** is the vertical distance the visible steam travels from the steam discharge.  
 Objects in the direct line of the visible steam or objects that are cooler than the ambient temperature may accumulate condensation.  
**Note:** Data above based on 70°F room temperature.

296/435 CFM Fan  
120/1/60\*, 2.17 amps  
1/15 HP

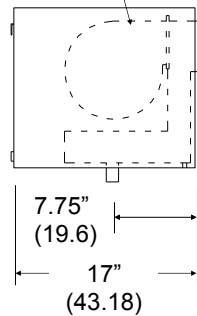

**Left Side View**

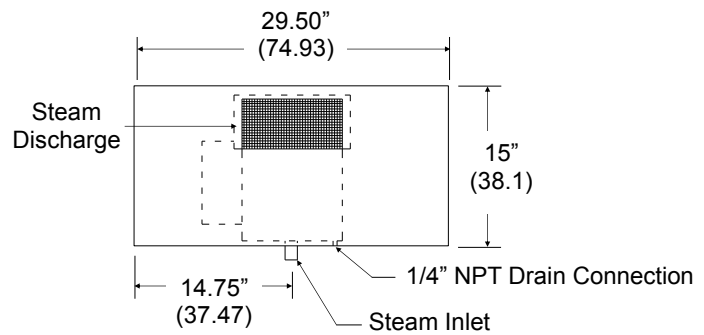

**Front View**

### Optional Blower Pack Dimensions

**Fig. 5**

Blower Pack weight is 60 lbs (27.2 kg)

\* Blower requires a separate 120/1 circuit (by others)



**Specification Sample**  
**"ECDDR" Series**

Sheet No.  
**ECDDR-8**

**Humidifier**

1. The humidifier shall be an electrically heated immersion heater type as manufactured by PURE Humidifier Co. of Chaska, Minnesota.
2. The humidifier shall be tested and approved by ETL/ETL-C Testing Laboratories, Inc.
3. The humidifier shall be suitable for use with deionized, demineralized or reverse osmosis water with a maximum purity of 18 mega ohms per sq. centimeter.
4. The humidifier shall have an evaporating reservoir with a gasket sealed cover which is capable of operating at pressures of at least 19"-48 cm (W.C.) without steam or water leaks. The reservoir shall be made of type 304L stainless steel with welded joints. Reservoir shall be mounted on slide rails for easy removal from the cabinet.
5. The reservoir shall be contained within a cabinet that is constructed of 18-gauge steel with a baked enamel finish. The cabinet floor shall be designed as a drain pan with plumbing connections for drain piping.
6. A stainless steel float operated low water cut-off switch shall be provided. The float switch shall provide positive low water cut-off of the humidifier immersion heaters.
7. A stainless steel float operated water fill valve mounted on the top of the humidifier shall be provided. The fill valve shall provide automatic refilling of the humidifier reservoir. The water inlet shall be located to allow a minimum water gap of 1 1/2" (3.81 cm).
8. The humidifier shall have a 3/4" (1.9 cm) overflow pipe to prevent overflowing of the humidifier reservoir.
9. A 1/2" stainless steel ball valve shall allow for manual draining of the humidifier reservoir.
10. The immersion heater(s) shall be incoloy clad and designed for 80 watts per sq. inch. They shall be attached to the reservoir cover and be easily removed for cleaning and inspection. Expansion and contraction of the heater(s) sheath allows mineral buildup to flake off.
11. The humidifier shall have a manual reset over-temperature switch factory installed on the humidifier reservoir. The temperature switch shall provide humidifier over-temperature protection.
12. A solid state, plug-in type control module shall be factory mounted within the control panel and shall electronically control the low water cut-off and safety switch interlock functions. The control module shall incorporate LED lights to indicate Safety Circuit Open, Power, Water Level Full and Heater Energized.
13. SCR Modulation, 100% solid state power controller shall be provided in the control panel. The SCR power controller will modulate the humidifier between 0-100% of its rated capacity according to humidistat demand.
14. The electrical compartment shall be isolated and watertight from the reservoir compartment. The electrical compartment shall be accessible by a hinged and key-locked door. The panel shall include a factory wired subpanel with a magnetic contactor, fused control circuit transformer, numbered terminal block and heater fuses. The high voltage wiring shall be shielded to prevent shock hazard. The modulating control voltage shall be field adjustable to match the controlling input signal.
15. The control cabinet shall have a factory wired time delay circuit. The delay circuit shall prevent cycling of the low water interlock due to water fluctuations within the humidifier reservoir.
16. The humidifier shall be supplied with a wall mount channel bracket for easy wall mounting. The bracket shall be load tested to a 600-pound capacity.

**Reference the "Options" page for a description of the options which can be added to the base specification.**





## Options "ECDDR" Series

Sheet No.  
**ECDDR-9**

### Humidifier

**Insulation.** Unit shall be covered (except top cover) with 3/4" (1.9 cm) thick fiberglass duct insulation. Insulation material shall have aluminum foil facing.

**Standby Water Temperature Sensing.** Consists of a temperature sensor to maintain water temperature at a selected level for fast response upon a call for humidity.

**Blower Pack.** Unit shall allow for direct space humidification without the use of ductwork. Unit shall be contained within a cabinet that is constructed of 18-gauge steel with a baked enamel paint finish. Unit shall have a two-speed field adjustable fan. The fan is controlled by a thermostat interlock mounted on the steam distributor, it shall activate the fan before steam is discharged and deactivate the fan after all residual steam has been discharged. The blower shall be designed to mount directly on top of the "ECDDR" humidifier or remote wall mounting.

### Injection Tubes

**Injection Tube(s) and Flexible Hose.** Each unit shall include one or more 10-foot (305 cm) sections of 1½" (3.8 cm) I.D. flexible hose and a 1½" (3.8 cm) O.D. stainless steel injection tube long enough to extend across the duct. Steam ports shall direct steam upward into the airflow. The reservoir cover shall have a matching connection so the flexible hose can be connected with two stainless steel hose clamps. A two-piece duct plate shall be provided to seal the duct opening.

**Fast-Pac Multiple Tube Assembly.** Tube assembly consists of a stainless steel supply/condensate header with a 3/4"-NPT drain connection and horizontal 1½"Ø stainless steel injection tubes.

**Insty-Pac Tube Assembly.** Tube assembly consists of a steam supply/seperator header constructed of stainless steel with steam inlet, condensate drain outlet, and steam jacketed injection tubes welded to header. Steam jacketed injection tubes constructed of stainless steel with punched steam ports of the proper size and spacing to deliver the maximum specified capacity.

**High Efficiency Insulated Tubes.** Thermoplastic wrap reduces condensate loss and unwanted heat gain during cooling mode.

### Controls and Safety Devices

**VAV Control.** A dual input, single output humidistat shall be supplied to provide a single modulating output signal to the humidifier control cabinet. The humidistat shall allow the use of a modulating wall mount sensor and modulating duct high-limit sensor (optional) to control critical variable air volume (VAV) air handling systems. The system shall automatically determine which of the two modulating signals is dominant and slowly reduces the humidifier output capacity, thus preventing over-saturation of the VAV system.

**Outdoor Air Temperature Setback.** Provides automatic reduction of RH set point to prevent condensation on windows during extreme cold weather.

**Airflow Proving Switch.** A diaphragm operated airflow proving switch with adjustable control range of .05" W.C. to 12.0" W.C. shall be provided for field installation. Switch rating shall be 2.5 amps at 120V.

**Duct High-Limit.** A high-limit humidistat shall be provided for duct installation. The high-limit shall be field set to prevent over saturation within the supply duct.

### Miscellaneous Accessories

**DCT-927 Drain Tempering Kit.** Provides cold water mixing of the 212°F drain water.

**Condensate Pump.** Used to lift condensate from the humidifier or tube assembly.

**INTAC® Microprocessor Controller.** The controller shall be factory-mounted and wired on the electrical compartment door. The INTAC® shall provide 16-character digital display of all functions, high/low humidity deviation alarms, time to service shall be capable of *flash memory upgrades* through EIA-485 terminal connections. Software updates shall be capable of being provided to customer via e-mail or Internet.

**Communications Gateway.** Allows Modbus to communicate with BACnet or LonWorks networks. Gateway can be used concurrently as a cloud connected device for secure remote access for diagnostics, monitoring, alarming and configuration of humidifier in the field. Wi-Fi connectivity can be enabled if desired. Must be used in conjunction with INTAC® microprocessor.