



Deionized, Demineralized, or Reverse Osmosis Water

“ESDDR” Series Electric Humidifier

The “ESDDR” Series Electric Humidifier from PURE Humidifier Co. is loaded with features and options. All you need is deionized, demineralized, or reverse osmosis water, electricity, and a sanitary drain. The humidifier does the rest.

These units are designed to operate with absolutely pure water, which is corrosive and will not conduct electricity. They feature special stainless steel construction with special assembly techniques to assure corrosion-resistant joints.

The water level is maintained with a special float valve to control the water level (instead of the Tri-Probe electronic water level controller that is utilized on the “ES” Series). A low water cut-off switch is utilized to protect the heating elements. Both floats are protected from water turbulence by an internal baffle. Since the reservoir’s water level is automatically and constantly adjusted, there is no downtime; steam is always available.

A control panel with a microprocessor controller mounted on the panel door constantly monitors the humidifier cycle for efficient operation. The microprocessor controller also provides a display to indicate the status of the humidifier. High efficiency immersion water heaters (up to twelve) heat the water to provide steam. Furthermore, a water overflow safety pipe is standard on all “ESDDR” units.

Since the water mineral buildup does not occur with pure water, there is no need for an automatic drain system or cleaning. These units are practically maintenance-free.

When it comes to installation, you have a choice with the “ESDDR” Series Electric Humidifier. The humidifier can be free-standing with a simple (optional) flexible hose connecting the unit to the stainless steel injection tube inserted through the duct wall. You can also mount the unit on the wall with wall brackets, or floor-mounted with support legs (both optional). For mounting under a duct, you simply need hangers and support brackets.

Fast-Pac or Insty-Pac tube assemblies can be provided for short dissipation in any built-up or manufactured air handling system.

The versatility of the “ESDDR” Series Electric Humidifier will allow you to design them into any system simply, efficiently, and reliably.

Our results are comforting



Capacities & Weight
“ESDDR” Series

Sheet No.
ESDDR-2

Model	Steam Output Capacity †		KW	Humidifier Reservoir Weight*				Control Cabinet Weight Δ	
	lbs/hr	kg/hr		Empty		Full		lbs	kg
ESDDR-3	9.0	4.1	3	50.5	22.9	130.5	59.2	32.0	14.5
ESDDR-4.5	13.5	6.1	4.5	50.5	22.9	130.5	59.2	32.0	14.5
ESDDR-5.5	18.0	8.1	6.0	50.5	22.9	130.5	59.2	32.0	14.5
ESDDR-7.5	22.5	10.2	7.5	50.5	22.9	130.5	59.2	32.0	14.5
ESDDR-11	31.5	14.2	10.5	50.5	22.9	130.5	59.2	32.0	14.5
ESDDR-14	40.5	18.4	13.5	50.5	22.9	130.5	59.2	32.0	14.5
ESDDR-15	45.0	20.4	15	50.5	22.9	130.5	59.2	32.0	14.5
ESDDR-16.5	49.5	22.5	16.5	50.5	22.9	130.5	59.2	32.0	14.5
ESDDR-19.5	58.5	26.5	19.5	50.5	22.9	130.5	59.2	32.0	14.5
ESDDR-22	63.0	28.6	21	61.0	27.7	177.0	80.3	55.0	25.0
ESDDR-28	81.0	36.7	27	61.0	27.7	177.0	80.3	55.0	25.0
ESDDR-30	90.0	40.8	30	61.0	27.7	177.0	80.3	55.0	25.0
ESDDR-33	99.0	45.0	33	61.0	27.7	177.0	80.3	55.0	25.0
ESDDR-39	117.0	53.1	39	61.0	27.7	177.0	80.3	55.0	25.0
ESDDR-42	126.0	57.2	42	61.0	27.7	177.0	80.3	55.0	25.0
ESDDR-45	135.0	61.2	45	65.5	29.7	181.5	82.3	72.0	32.7
ESDDR-49.5	148.5	67.4	49.5	65.5	29.7	181.5	82.3	72.0	32.7
ESDDR-58.5	175.5	80.0	58.5	65.5	29.7	181.5	82.3	72.0	32.7
ESDDR-63	189.0	85.7	63	65.5	29.7	181.5	82.3	72.0	32.7
ESDDR-66	198.0	89.8	66	88.0	39.9	243.0	110.2	72.0	32.7
ESDDR-78	234.0	106.1	78	88.0	39.9	243.0	110.2	72.0	32.7
ESDDR-84	252.0	114.3	84	88.0	39.9	243.0	110.2	72.0	32.7
ESDDR-102	306.0	138.8	102	88.0	39.9	243.0	110.2	72.0	32.7

* When calculating the total dry weight of the humidifier, the control cabinet weight must be added to the reservoir weight. Δ The control cabinet is shipped loose unless optional factory mounting is specified. Reference the “Dimension Sheet” for control cabinet dimensions.

† The above capacities are based on 100% nominal efficiency. Actual humidifier capacity may vary due to the heat loss from the humidifier reservoir. The ambient air temperature, air velocity, and injection tube system will affect the rate of heat loss from the humidifier reservoir. This can also be affected by makeup water temperature, voltage variations, carry-over losses, heater resistance tolerance, etc.

NEMA- 12 Humidifier Control Cabinet
(reference control cabinet notes)

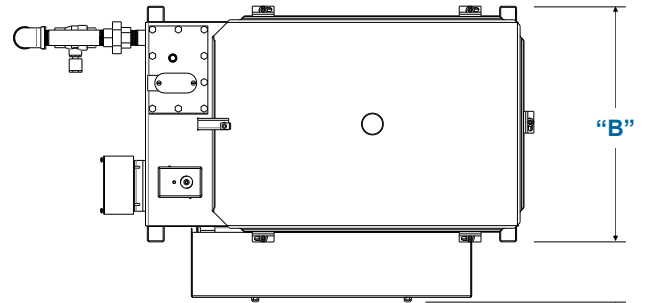
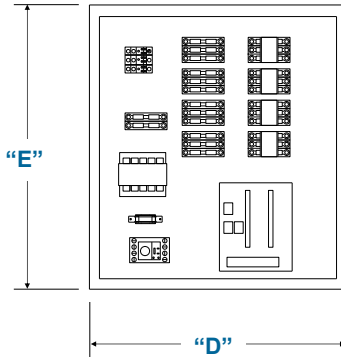

Top View

1. Door has been removed from the drawing for clarity.
2. Control cabinet is shipped loose for field mounting unless optional factory mounting is specified.
3. Dimension “F” = Control cabinet depth.

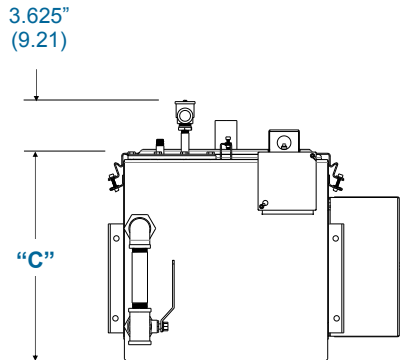

Front View

Steam Outlet Connection
(size and qty. will vary with application)

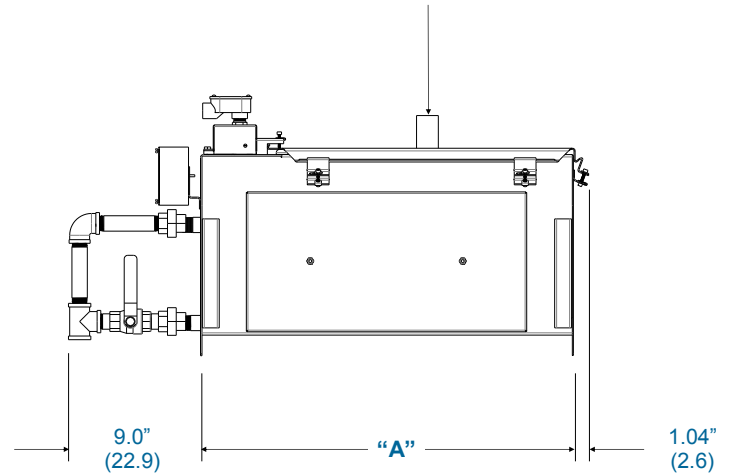

Right Side View

Unit Dimensions						
Model	Dim. “A”		Dim. “B”		Dim. “C”	
	inches	cm	inches	cm	inches	cm
ESDDR-3 thru 19.5	17.68”	44.9	16.21”	41.2	13.84”	35.2
ESDDR-22 thru 63	25.68”	65.2	16.21”	41.2	13.84”	35.2
ESDDR-66 thru 102	34.18”	86.8	20.46”	52.0	13.84”	35.2

Control Cabinet Dimensions						
Model	Dim. “D”		Dim. “E”		Dim. “F”	
	inches	cm	inches	cm	inches	cm
ESDDR-3 thru 19.5	14.00	35.6	16.00	40.6	6.00	15.2
ESDDR-22 thru 63	20.00	50.8	20.00	50.8	7.00	17.8
ESDDR-66 thru 102	20.00	50.8	24.00	61.0	7.00	17.8
ESDDR-*	24.00	61.0	30.00	76.2	7.00	17.8

* Control panel for use with units requiring amp draws of 123 or higher



Electrical Specifications "ESDDR" Series

Sheet No.
ESDDR-4

Single Phase Amperage†

Model	Unit KW	120V	208V	240V	480V	600V	No. of Heaters	Heater KW	Control Circuit Voltage
ESDDR-3	3	25.0	14.4	12.5	6.3	5.0	3	1.0	24 vac
ESDDR-4.5	4.5	37.5	21.6	18.8	9.4	7.5	3	1.5	24 vac
ESDDR-5.5	6.0		28.8	25.0	12.5	10.0	3	2.0	24 vac
ESDDR-7.5	7.5		36.1	31.3	15.6	12.5	3	2.5	24 vac
ESDDR-11	10.5				21.9	17.5	3	3.5	24 vac
ESDDR-14	13.5				28.1	22.5	3	4.5	24 vac
ESDDR-15	15				31.3	25.0	3	5.0	24 vac
ESDDR-16.5	16.5				34.4	27.5	3	5.5	24 vac
ESDDR-19.5	19.5				40.6	32.5	3	6.5	24 vac
ESDDR-22	21				43.8	35.0	6	3.5	24 vac
ESDDR-28	27				56.3	45.0	6	4.5	24 vac
ESDDR-30	30				62.5	50.0	6	5.0	24 vac
ESDDR-33	33				68.8	55.0	6	5.5	24 vac
ESDDR-39	39				81.3	65.0	6	6.5	24 vac
ESDDR-42	42				87.5	70.0	6	7.0	24 vac
ESDDR-45	45				93.8	75.0	9	5.0	24 vac
ESDDR-49.5	49.5				103.1	82.5	9	5.5	24 vac
ESDDR-58.5	58.5				121.9	97.5	9	6.5	24 vac
ESDDR-63	63				131.3	105.0	9	7.0	24 vac
ESDDR-66	66				137.5	110.0	12	5.5	24 vac
ESDDR-78	78				162.5	130.0	12	6.5	24 vac
ESDDR-84	84				175.0	140.0	12	7.0	24 vac
ESDDR-102	102					170.0	12	8.5	24 vac

Single phase units may have varying number of heating elements.

Three Phase Amperage†

Model	Unit KW	208V	240V	480V	600V	No. of Heaters	Heater KW	Control Circuit Voltage
ESDDR-3	3	8.3	7.2	3.6	2.9	3	1.0	24 vac
ESDDR-4.5	4.5	12.5	10.8	5.4	4.3	3	1.5	24 vac
ESDDR-5.5	6.0	16.6	14.4	7.2	5.8	3	2.0	24 vac
ESDDR-7.5	7.5	20.8	18.0	9.0	7.2	3	2.5	24 vac
ESDDR-11	10.5	29.1	25.3	12.6	10.1	3	3.5	24 vac
ESDDR-14	13.5	37.5	32.4	16.2	13.0	3	4.5	24 vac
ESDDR-15	15	41.6	36.1	18.0	14.4	3	5.0	24 vac
ESDDR-16.5	16.5	45.8	39.7	19.8	15.9	3	5.5	24 vac
ESDDR-19.5	19.5			23.5	18.8	3	6.5	24 vac
ESDDR-22	21	58.3	50.5	25.3	20.2	6	3.5	24 vac
ESDDR-28	27	75.0	64.9	32.5	26.0	6	4.5	24 vac
ESDDR-30	30	83.3	72.2	36.1	28.9	6	5.0	24 vac
ESDDR-33	33	91.6	79.4	39.7	31.8	6	5.5	24 vac
ESDDR-39	39			46.9	37.5	6	6.5	24 vac
ESDDR-42	42			50.5	40.4	6	7.0	24 vac
ESDDR-45	45	124.9	108.3	54.1	43.3	9	5.0	24 vac
ESDDR-49.5	49.5	137.4	119.1	59.5	47.6	9	5.5	24 vac
ESDDR-58.5	58.5			70.4	56.3	9	6.5	24 vac
ESDDR-63	63			75.8	60.6	9	7.0	24 vac
ESDDR-66	66			79.4	63.5	12	5.5	24 vac
ESDDR-78	78			93.8	75.1	12	6.5	24 vac
ESDDR-84	84			101.0	80.8	12	7.0	24 vac
ESDDR-102	102			122.7	98.2	12	8.5	24 vac

† Other voltages available upon request. Please consult factory for specific availability.

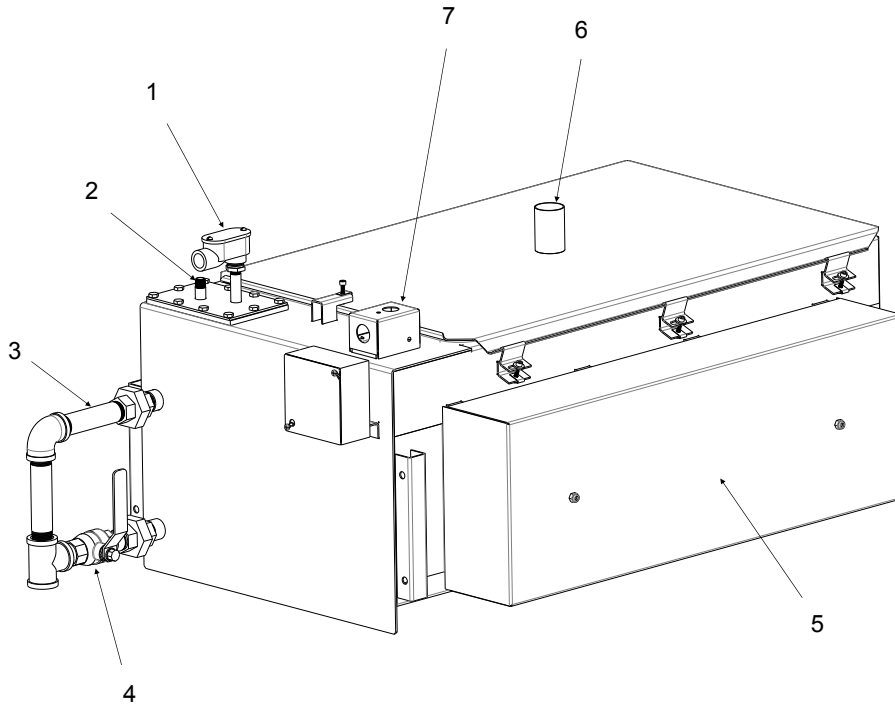

Features

- | | |
|--|---------------------------------------|
| 1. Low Water Float Switch Junction Box | 4. 3/4" NPT Ball Valve |
| 2. 1/4" NPT Fill Inlet Connection | 5. Heater Assembly Access |
| 3. Overflow Piping | 6. Humidifier Steam Outlet Connection |
| | 7. Over Temperature Cut-Out Switch |

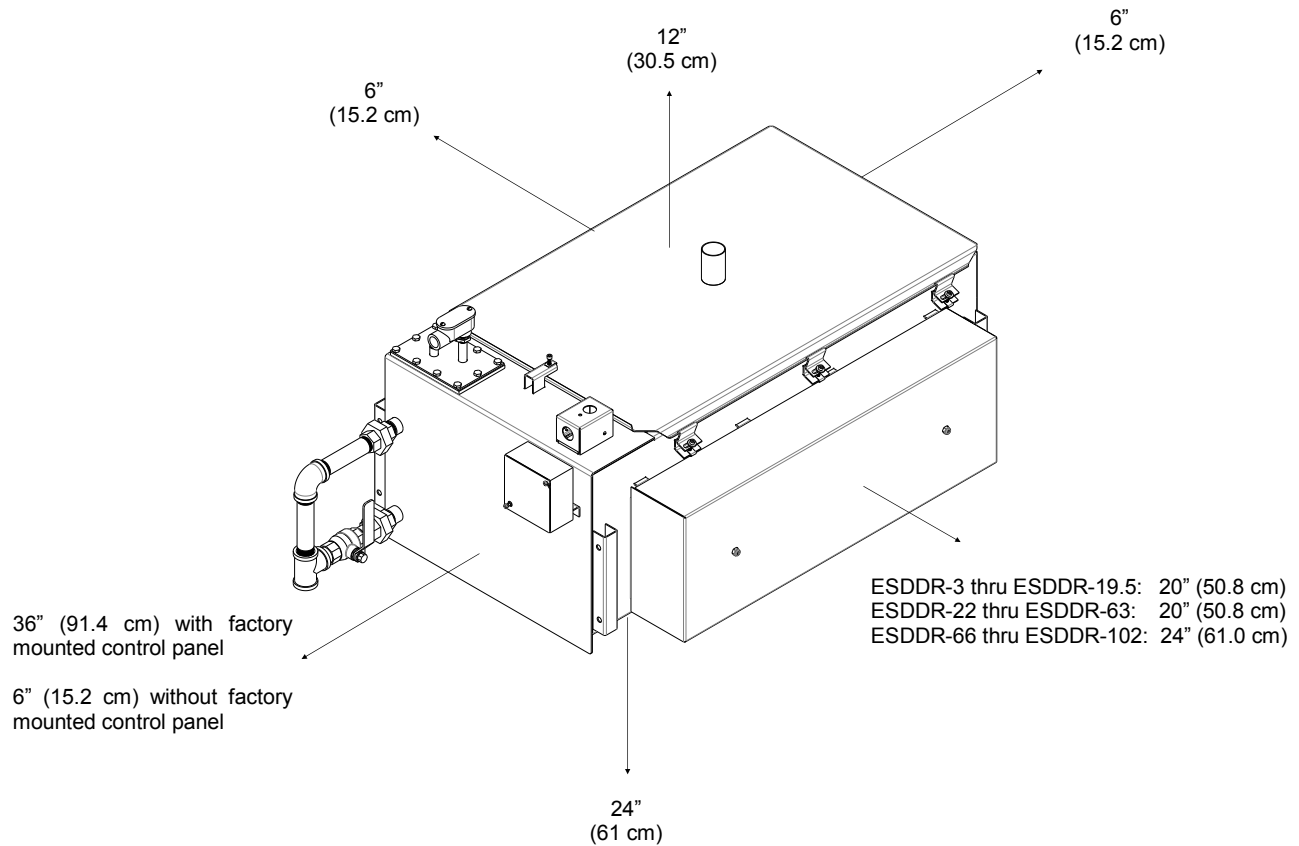

Mounting Location Considerations

Install in a location where the ambient air temperature is between 40°F - 100°F (4.4°C - 37.8°C) and relative humidity between 0% - 90% and non-condensing.

Install in a location where there is easy access to a water supply, electrical supply, and open sanitary drain.

Install as close as possible to the steam distribution grid.

Clearances shown are minimum recommendations only. Please consult local and national codes for final installation location.

Do not install where humidifier operational noise will be a nuisance.

Allow enough room for proper water seals depths.

Do not install above any critical processes, equipment, or locations in case of a water leak.

Do not install near variable frequency drives, electromagnetic equipment, or motors.

SCR RELAY CLEARANCE NOTE

When SCR modulating control is supplied on a non-factory mounted control panel you will need to leave 12" clearance on the sides of the panels where the SCR heat sinks are located.



Mounting Applications "ESDDR" Series

Sheet No.
ESDDR-7

The "ESDDR" Series Electric Humidifier offers a wide variety of mounting applications. If the duct is remote from the humidifier reservoir, free-standing floor support legs or wall brackets (both optional) are available. Single or multiple injection tubes can be used to custom fit any duct or air handler size.

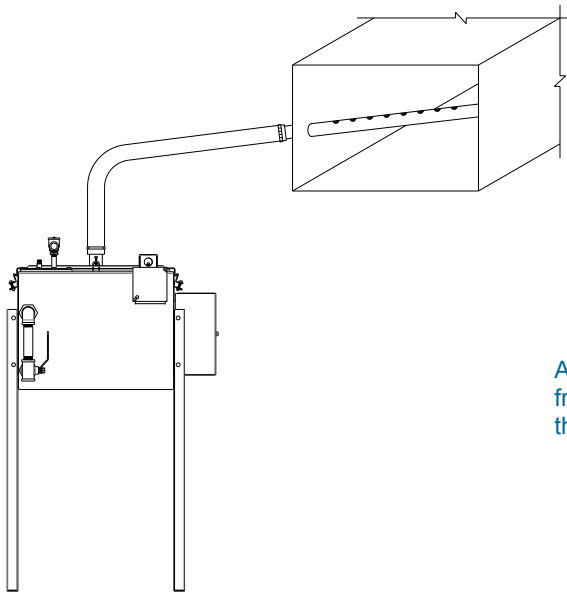

Free Standing Support Legs (optional)

Allows remote mounting of the humidifier reservoir from the duct. The humidifier is supported 24" from the floor.

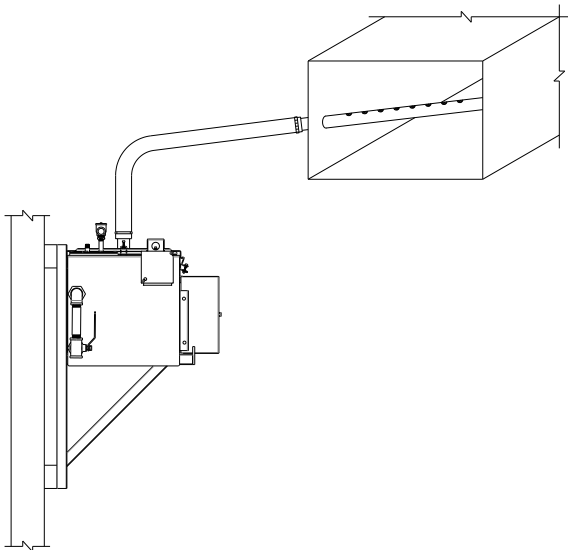

Wall Mounting Brackets (optional)

Allows remote mounting of the humidifier reservoir from the duct, or it can be used to mount the humidifier beneath a wall mounted duct.



Specification Sample
"ESDDR" Series

Sheet No.
ESDDR-8

Humidifier

1. The humidifier shall be an electrically heated immersion heater type as manufactured by PURE Humidifier Co. of Chaska, Minnesota.
2. The humidifier shall be tested and approved by ETL/ETL-C Testing Laboratories, Inc.
3. The humidifier shall be suitable for use with pure water such as deionized, demineralized or reverse osmosis water with a maximum purity of 18 megohm-cm.
4. The humidifier shall have an evaporating reservoir with a gasket sealed cover which is capable of operating at pressures of at least 19"-48 cm (W.C.) without steam or water leaks. The reservoir shall be made of type 304L stainless steel with welded joints.
5. The humidifier shall be designed to facilitate easy removal of the heater assembly for inspection. The cover and heater assembly shall be secured to the unit by the use of quick release clamps. The heater assembly shall be removable from the side of the humidifier without disturbing the cover or injection tube system's steam supply piping.
6. Humidifier shall be field convertible from an electric immersion heater style "ESDDR" humidifier to a steam heat exchanger style "SXDDR" humidifier with a simple change of the side entry assembly.
7. A stainless steel float operated low water cut-off switch shall be provided. The float switch shall provide positive low water cutout of the humidifier immersion heaters.
8. The immersion heater(s) shall be incoloy clad and designed for 80 watts per sq. inch. Expansion and contraction of the heater(s) sheath allows mineral buildup to flake off.
9. A stainless steel float operated water fill valve mounted on the top of the reservoir near the front shall be provided. The fill valve shall provide automatic refilling of the humidifier reservoir. The water inlet shall be located to allow a minimum water gap of 1 1/2" (3.81 cm).
10. The humidifier shall have a 3/4" (1.9 cm) overflow pipe to prevent overfilling of the humidifier reservoir.
11. A 3/4" stainless steel ball valve shall allow for manual draining of the humidifier reservoir.
12. The humidifier shall have a manual reset over-temperature switch factory installed on the humidifier reservoir. The temperature switch shall provide humidifier over-temperature protection.
13. The humidifier shall be provided with an ETL listed JIC NEMA 12 control cabinet, shipped loose (reference factory mounting option). The control cabinet shall be made of 14-gauge steel with ANSI 61 gray polyester powder coating, continuous hinge and oil-resistant gasket. The panel shall include a factory wired subpanel with magnetic contactor(s), low voltage relay, fused control circuit transformer, numbered terminal block and heater fuse(s).
14. SCR Modulation. Provides 0-100% power modulation of the heater outputs down to a one-second cycle rate. All heater sets have full SCR control.
15. An INTAC[®] programmable electronic microprocessor humidifier control system shall be mounted and pre-wired to the humidifier control panel door. The INTAC[®] controller shall provide digital display of all humidifier functions.

Reference the "Options" page for a description of the options which can be added to the base specification.



INTAC[®] Specification Sample "ESDDR" Series

Sheet No.
ESDDR-9

An INTAC[®] programmable electronic microprocessor humidifier control system shall be mounted and pre-wired to the humidifier control panel door. All humidifier electrical, ground and control terminal connections shall be enclosed in an ETL listed NEMA 12 enclosure. The INTAC[®] controller shall provide the following standard features:

- Self-diagnostics and system verification on start-up.
- Evaporating reservoir water level verification, control and safety interlock.
- Safety circuit input terminals including over-temperature shut down.
- Terminal connections to accept virtually all control input signals. Input control range is selected as an "ON-SCREEN" prompt.
- User adjustable controlling and high-limit RH PID functions with adjustable parameters (if utilized).
- Door-mounted display and user interface. Provides multiple lines of system messaging on a display screen, LED operational indication and keypad parameter entry system.
- Display brightness is adjustable.
- Adjustable input signal filter to attenuate noisy control input signal.
- Numbered screen prompts for set-up and service identification.
- Keypad lock-out with user selected access levels.
- Time-delayed scrolling display loop will begin cycling ten minutes after no buttons have been pressed and will display the next item for 30 seconds before continuing down the list – displays system parameters including: Low and High RH Alarms, System Faults, System Status, Set Point and Actual Space RH, Set Point and Actual Duct RH (optional), Outdoor Air Temperature (optional), Percent Power Output, Humidifier Output (in lbs/hr or kg/hr), Accumulated Run Time, Time to Clean timer, Water Level, Water Temperature Set Point and Actual (optional) and Control Type.
- Full Networking and BAS communication capability. Communication connections shall provide two-way communication via EIA-485 connected Modbus between the INTAC[®] controller and the Building Automation System (BAS) (if utilized).
- High/Low humidity deviation alarm contacts (modulating control only).
- Multiple humidifiers can run off of one control signal from a BAS system. Humidifiers can be set up to run in parallel or in series.
- Safety Circuit/System Fault/Low Water alarm contacts.
- Flash Memory – allows system upgrades through EIA-485 terminal connections.
- SCR Modulation. Provides 0-100% power modulation of the heater outputs down to a one-second cycle rate. All heater sets have full SCR control.

OPTIONAL CONTROL FEATURES TO BASE SPECIFICATION

- A. Variable air volume (VAV) anticipation control. The INTAC[®] software shall accept a modulating high-limit humidity input and space controlling RH input, then modulates the heater output to prevent over saturation of the supply air due to changes in the quantity of airflow. A compatible humidity sensor shall be shipped loose for field installation.
- B. Cold weather relative humidity reset. The INTAC[®] software shall accept a modulating temperature input and automatically reduce the space RH set-point on a drop in the outside temperature. The reduction of the RH set-point during cold weather periods prevents damage due to interior window condensation.
- C. Reservoir thermocouple water temperature control. The INTAC[®] software provides standby water temperature sensing and freeze protection.
- D. DDR Seasonal "End-Of-Use" humidifier drain. The humidifier will automatically drain the reservoir after a non-use time period which is field adjustable. Upon receiving a call for humidity, the system automatically refills the reservoir and allows the humidifier to operate in "Normal Mode". System uses a stainless steel solenoid fill valve and stainless steel motorized drain valve.

Reference the "Specification Sample" for the humidifier base specification.



Options "ESDDR" Series

Sheet No.
ESDDR-10

Humidifier

Insulation. Unit shall be covered (except top cover) with 3/4" (1.9 cm) thick fiberglass duct insulation. Insulation material shall have aluminum foil facing.

Freeze Protection. A factory-installed temperature sensor shall be mounted onto the humidifier reservoir. The system shall maintain the water temperature above freezing.

Standby Water Temperature Sensing. Consists of a temperature sensor to maintain water temperature at a selected level for fast response upon a call for humidity.

DDR Seasonal End of Use Drain. Provides automatic seasonal drain of reservoir. Will drain water from the humidifier tank after a period of time with no humidity demand.

Mounting

Support Legs. Provide support legs made of 1¹/₄" x 1¹/₄" x 1¹/₄" (3.2 cm) angle iron and painted with enamel gray paint. Distance from humidifier bottom to floor shall be 24" (61 cm).

Wall Brackets. Provide two wall brackets made of 1¹/₄" x 1¹/₄" x 1¹/₄" (3.2 cm) angle iron and painted with enamel gray paint.

Injection Tubes

Injection Tube(s) and Flexible Hose. Each unit shall include one or more 10-foot (305 cm) sections of 1¹/₂" (3.8 cm) I.D. flexible hose and a 1¹/₂" (3.8 cm) O.D. stainless steel injection tube long enough to extend across the duct. The reservoir cover shall have a matching connection so the flexible hose can be connected with two stainless steel hose clamps. A two-piece duct plate shall be provided to seal the duct opening.

Blower Pack. Blower pack consists of a two-speed blower contained in an 18-gauge steel cabinet with a factory mounted and wired temperature interlock. Blower Pac maximum steam capacity is 102 lbs/hr.

Fast-Pac Multiple Tube Assembly. Tube assembly consists of a stainless steel supply/condensate header with a 3/4"-NPT drain connection and horizontal 1¹/₂"Ø stainless steel injection tubes.

Insty-Pac Tube Assembly. Tube assembly consists of a steam supply/separater header constructed of stainless steel with steam inlet, condensate drain outlet, and steam jacketed injection tubes welded to header. Steam jacketed injection tubes constructed of stainless steel with punched steam ports of the proper size and spacing to deliver the maximum specified capacity.

High Efficiency Insulated Tubes. Thermoplastic wrap reduces condensate loss and unwanted heat gain during cooling mode.

To Control Cabinet

Control Cabinet Factory Mounting. Humidifier control cabinet shall be factory-mounted and wired to the humidifier reservoir.

NEMA 4 Control Cabinet. A NEMA 4 weather-tight control cabinet shall be substituted for the standard NEMA 12 cabinet.

Control Panel Door Lock. Control cabinet shall be provided with a factory-installed key lock on the cabinet door.

Controls and Safety Devices

Communications Gateway. Allows Modbus to communicate with BACnet or LonWorks networks. Gateway can be used concurrently as a cloud connected device for secure remote access for diagnostics, monitoring, alarming and configuration of humidifier in the field. Wi-Fi connectivity can be enabled if desired.

Airflow Proving Switch. A diaphragm operated airflow proving switch with adjustable control range of .05" W.C. to 12.0" W.C. shall be provided for field installation. Switch rating shall be at a minimum 2.5 amps at 120V.

Duct High-Limit. A high-limit humidistat shall be provided for duct installation. The high-limit shall be field set to prevent over saturation within the supply duct.

Miscellaneous Accessories

DCT-927 Drain Tempering Kit. Provides cold water cooling of the 212°F drain water.

Condensate Pump. Used to lift condensate from the humidifier or tube assembly.

Outdoor Enclosure. Galvanized steel enclosure with dual tank freeze protection, control panel mounted, support legs, insulated tank, ventilation and hinged access doors. Enclosure is ready to be curb-mounted with the humidifier pre-installed. Ships as one piece. Roof curb is not included.