

INSTY-PAC INTERNAL MOUNT MULTIPLE TUBE ASSEMBLY

INSTALLATION AND ASSEMBLY INSTRUCTIONS

Fig. 1

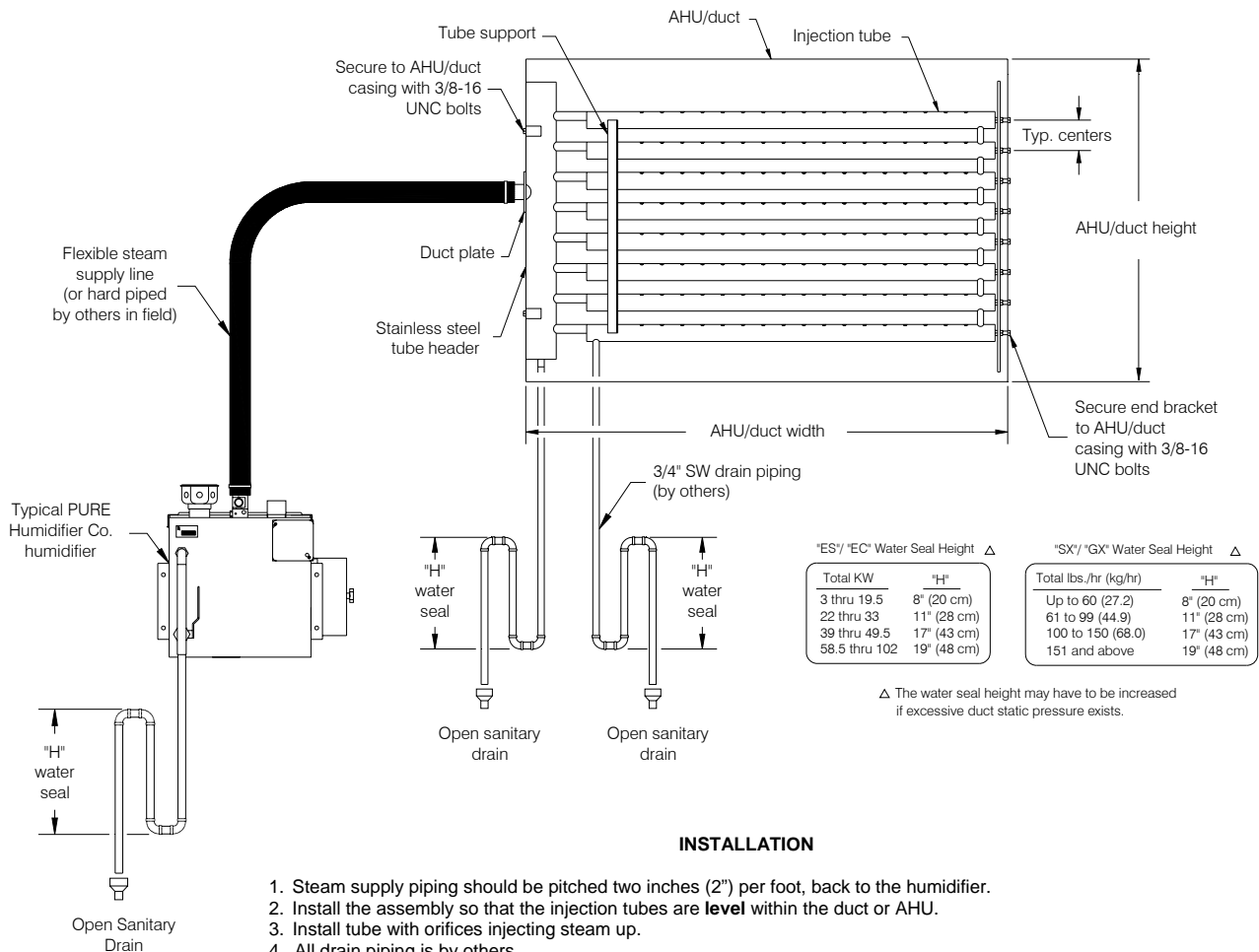

INSTALLATION

1. Steam supply piping should be pitched two inches (2") per foot, back to the humidifier.
2. Install the assembly so that the injection tubes are **level** within the duct or AHU.
3. Install tube with orifices injecting steam up.
4. All drain piping is by others.
5. Each condensate connection must have it's own water seal. Condensate connections cannot be combined together to a common water seal.
6. A common condensate drain line can be used after the individual water seals.

Introduction

Table of Contents

Introduction	1
Steam Supply Piping Examples	2
Mounting Instructions	3
Component Identification	4
Header & Support Bracket Mounting Detail	5
Installation Tips/Controls	6
Troubleshooting	7
Maintenance	8
Non-Wetting Distance Charts	9
Piping Capacities/Air Pressure Loss	10

To the user of PURE Humidifier Co.'s Electric Humidifiers

We at PURE Humidifier Co. thank you for choosing one of our quality products. PURE Humidifier Co. humidifiers are simple to install, operate, and maintain. However, they must be maintained to provide maximum operating efficiency.

PLEASE READ AND FOLLOW ALL INSTRUCTIONS CAREFULLY. PROPER OPERATION AND HUMIDITY CONTROL IS POSSIBLE ONLY WITH PROPER INSTALLATION AND MAINTENANCE.

To ensure proper installation of this product, it must be installed by qualified HVAC and electrical contractors, and must be in compliance with local, state, federal, and governing codes. If installed improperly this product may cause damage to property, severe personal injury, or death as a result of electric shock, burns, and/or fire.

The PURE Humidifier Co. Warranty

PURE Humidifier Co. guarantees its products to be free from defects in material and workmanship for a period of two years from the date of shipment; provided the product is properly installed, serviced, and put into the service for which it was intended.

PURE Humidifier Co. is obligated under the terms of this warranty to the repair or replacement of the defective part(s), excluding any labor charges, or to refund the purchase price at our option. PURE Humidifier Co. assumes no obligation for incidental or consequential damages. The above provisions are in lieu of all other guarantees, obligations, liabilities or warranties, expressed or implied.

Steam Supply Piping Examples

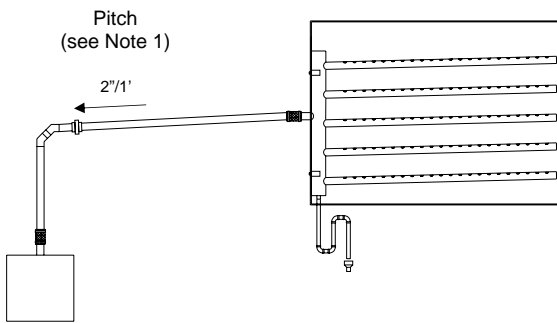

Pitched Towards Steam Generator

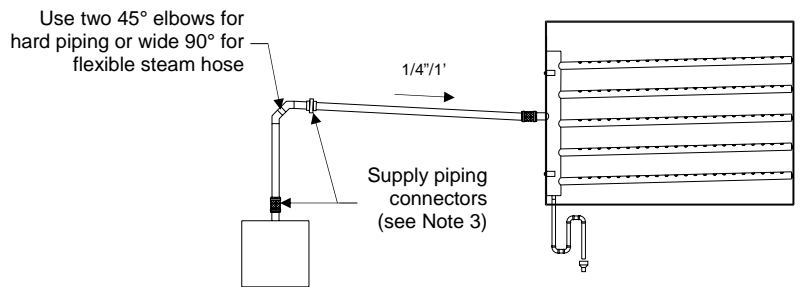

Pitched Towards Tube Assembly

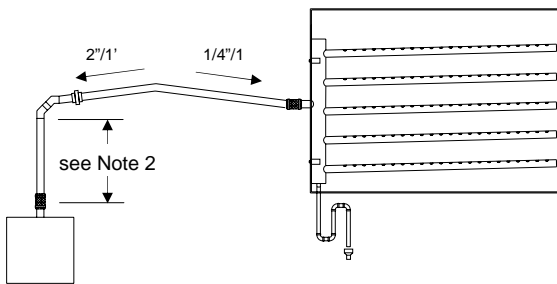

**Pitched Towards Steam Generator
and Tube Assembly**

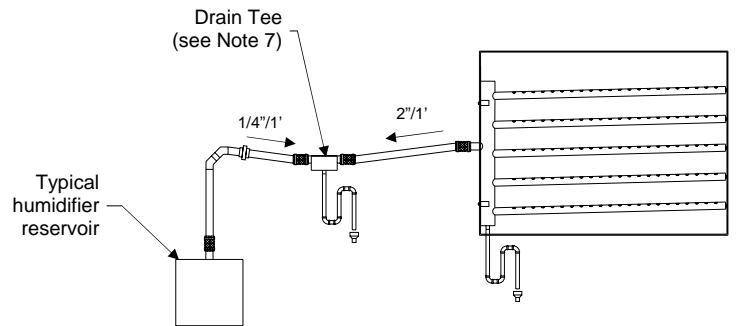

Pitched Towards Drain Tee

Notes:

1. Pitch hard piping or flexible hose 2" per foot if steam is flowing uphill, 1/4" per foot if the steam is flowing downhill. Reference piping examples shown.
2. When feasible to do so, install a minimum one-foot riser from the top of the tank to reduce condensate carry over.
3. Use flex connectors or unions to allow for easy removal of cover.
4. Support flexible hose every 18" to avoid sagging.
5. Hard piping or flexible hose must match reservoir outlet size. Do not use supply piping with a smaller inside diameter than the reservoir outlet.
6. Failure to follow the piping recommendation on this page may result in blown water seals, leaking cover gasket or dispersion tubes spitting.
7. Install a Drain Tee at any low spots in supply piping run where condensate will accumulate.

Insty-Pac Injection Tube Assembly Internal Mounting Instructions

The Insty-Pac tube assembly supplied with the humidifier(s), is designed for rapid dissipation of steam. The tube assembly is designed for *internal* AHU or duct mounting.

Verify Components

Unpack the components from the shipping container. Verify all components are checked off according to the packing list and the *COMPONENTS IDENTIFICATION DRAWING* (Fig. 2). Report any missing pieces to your local PURE Humidifier Co. representative immediately.

Location

1. Mount the injection tube assembly in the AHU or duct work as shown on the project plans or as indicated by the engineer.
2. Install the injection tube with the 3/4"-NPT drain connection, located on the tube header, directed towards the bottom of the AHU or duct.
3. Install the tube assembly so that the injection tubes are **level** within the AHU or duct.
4. Install the tube assembly with the steam discharge ports facing upwards.
5. The tube assembly should be centered in the AHU or duct height with an even distance between the bottom tube and the casing floor and the top tube and the casing ceiling.

Mounting

1. Layout the center lines for the injection tube SUPPLY and CONDENSATE connections. The supply connections outside diameter may vary, the condensate connection is 1-1/16" outside diameter. Duct plates are provided to seal the opening. The layout should be based on the "Location" instructions listed above (see Fig. 3).
2. Cut a hole through the AHU or duct wall for the supply connection. If the alternate horizontal condensate drain connection is supplied, cut a 1-1/16" diameter hole through the AHU or duct wall, for the drain connection (see Fig. 3).
3. Install the tube HEADER onto the inside of the AHU or duct wall with the steam supply connection installed through the access hole (cut in step above). Secure the header to the AHU or duct wall with 3/8-16 fasteners (by others). The HEADER is provided with header mounting brackets welded onto the header (see Fig. 2)
4. Secure the END BRACKET to the AHU or duct wall with 3/8-16 fasteners (by others). The END BRACKET must be located so that tubes are **level** (see Fig. 3).
5. Seal the openings where the STEAM SUPPLY and CONDENSATE connections penetrate through the AHU or duct wall with the duct plates provided (see Fig. 3).
6. Connect steam supply and condensate piping to the humidifier as illustrated in Fig. 1.

NOTE: For tube assemblies over 48" (122 cm) in length, allow for 1/2" (1.3 cm) of linear expansion of tubes. Not allowing for this expansion could cause system performance issues or cracking of welds.

Internal Mount Insty-Pac Tube Assembly
Component Identification

ITEM NO.	DESCRIPTION	QUANTITY
1	Supply/condensate header	1
2	Injection tubes	varies with order
3	Tube mounting bolts	1 per tube
4	Duct plate (supply)	1 per supply inlet
5	Duct plate (condensate)	1
6	Tube support bracket	1

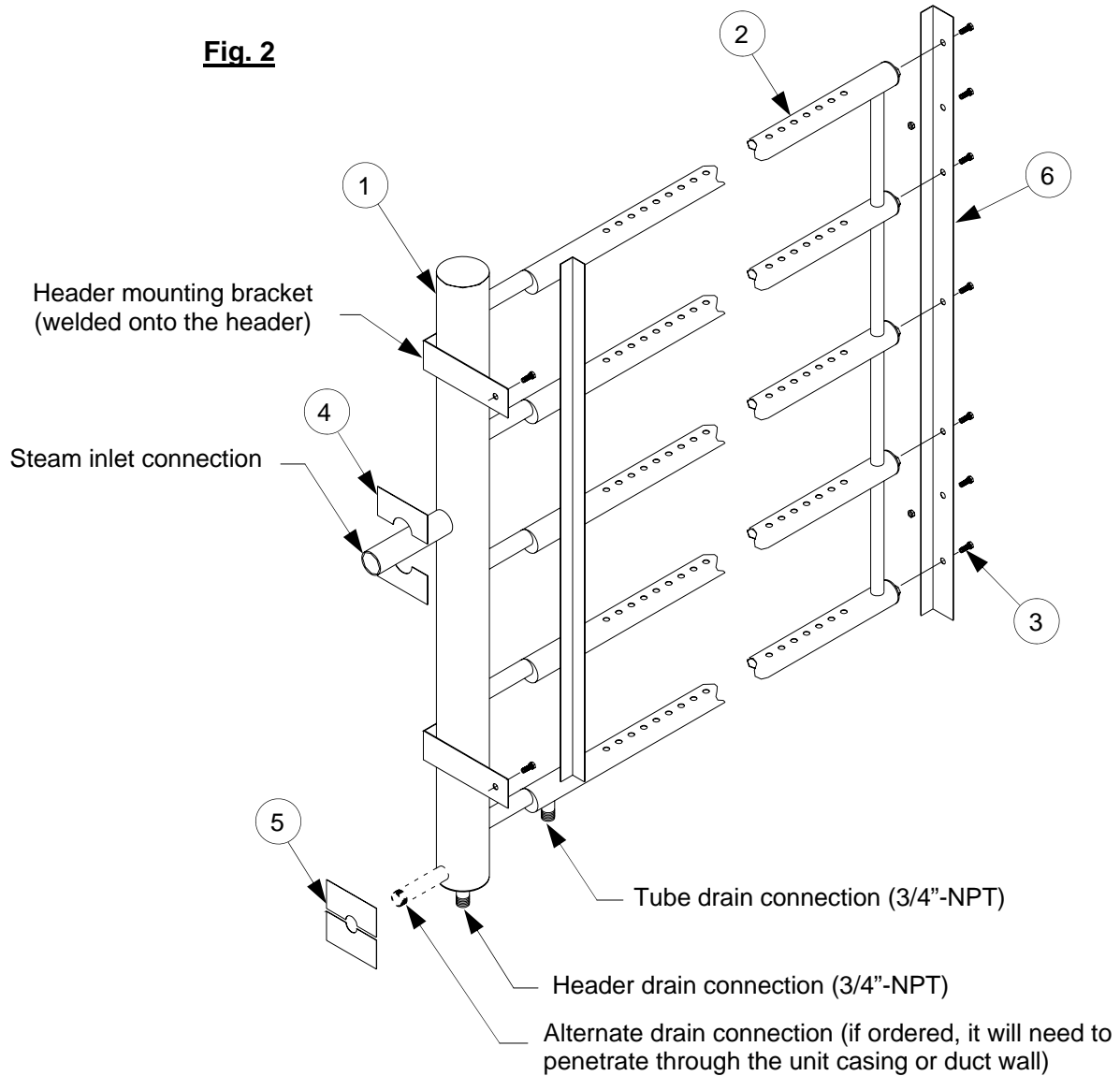

Header & Support Bracket Mounting Detail

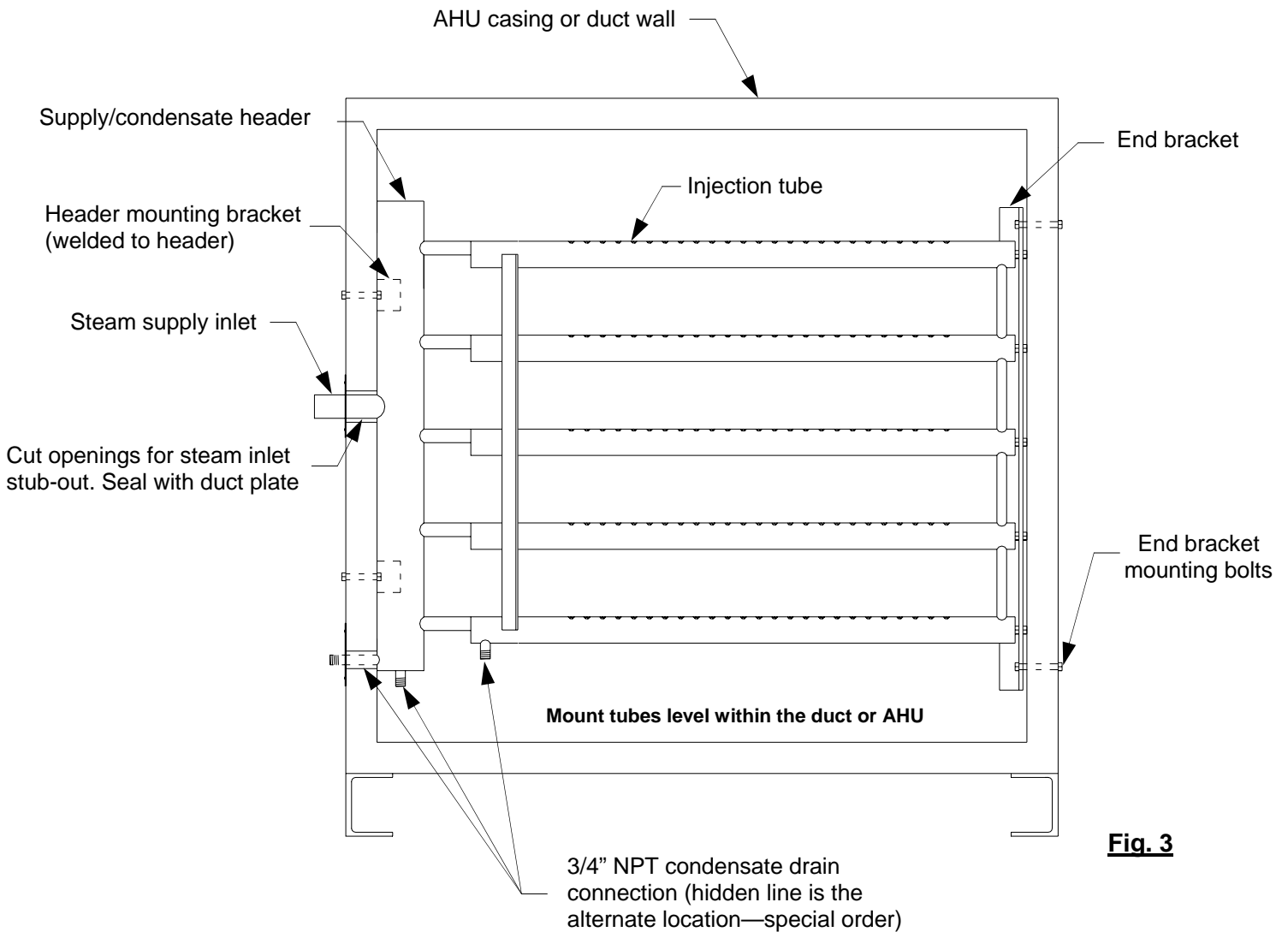

Notes:

1. Center the multiple injection tube assembly in the duct height.
2. The injection tubes should be mounted **level** within the duct or AHU.
3. Install injection tubes with the orifices injecting upwards.
4. All condensate drain piping is by others.
5. Condensate must drain by gravity to an open drain. Condensate cannot be elevated.
6. Each condensate connection must have it's own water seal. Condensate connections cannot be combined together to a common water seal.
7. A common condensate drain line can be used after the individual water seals.

Installation Tips

Condensate Return Line

Condensate from the header or tubes cannot be elevated. Do not connect water seals to pressurized condensate return lines. **The drain piping should be copper or stainless steel. The use of PVC piping is not recommended; the humidifier temperature will cause the PVC to soften and fail.**

Laminar air flow

Tube assembly must be installed in a location that allows for laminar air flow across entire grid. A minimum velocity of 300 feet per minute is required to avoid saturation and excessive fog travel. If gravity drain is not possible please use a condensate pump rated for 212°F water or contact a PURE Humidifier Co. representative to purchase one.

Plug fan installations

Install tube assembly as close as possible to the upstream coil to ensure laminar airflow and proper absorption.

Insulated ducts

Internally insulated ducts must be lined with a non-absorbent material to avoid saturation. If the duct is lined it must be removed three feet (3') upstream and ten feet (10') downstream of tube assembly.

Final Filters

Tube assembly must be installed a minimum of ten feet (10') upstream of final filters.

VAV Systems

Low velocity will cause long fog trails and steam will rise wetting the top of the AHU/duct casing. Modulating VAV high-limit humidistat is required. A minimum velocity of 300 feet per minute is required to avoid saturation and excessive fog travel.

Controls

Fan Interlock Switch

PURE Humidifier Co. recommends the use of an air flow proving switch or fan interlock to prove air flow prior to humidifier cooperation. Humidifier operation without air flow will result in over-saturation of the air stream. Air flow proving switches are available as optional equipment from your PURE Humidifier Co. representative.

High-Limit Humidistat

PURE Humidifier Co. recommends the use of a duct high-limit humidistat to prevent humidifier operation when the duct humidity level exceeds 85% relative humidity. Humidifier operation above 85% relative humidity can result in over-saturation of the air stream. High-limit humidistats are available as optional equipment from your PURE Humidifier Co. representative. The high limit humidistat should be 8 to 10 feet (244-305 cm) downstream from the humidifier injection tube. Installing the high-limit closer than 8 feet (244 cm) from the humidifier may cause erratic control.

Smoke Alarms and Temperature Sensors

Smoke alarms should be located 12 to 14 feet (365-427 cm) upstream from the humidifier injection tube.

Temperature sensors should be located 12 to 14 feet (365-427 cm) downstream from the humidifier injection tube, or past any visible fog travel that may be greater than this distance.

Troubleshooting

Too Much Humidity

1. Humidity controller out of calibration.
2. Humidifier oversized.
3. Check humidifier (GX, SX, ES, EC) for proper operation.

Too Little Humidity

1. Humidity controller out of calibration.
2. Undersized humidifier.
3. Check humidifier (GX, SX, ES, EC) for proper operation.
4. Water seals are not primed.
5. Water seals are blown due to improper supply piping.

Humidifier Discharges Water

1. Faulty drainage:
 - A) Return line pressure greater than humidifier pressure.
 - B) Return line flooded.
 - C) Vertical lift.
 - D) Tube assembly not level.

Maintenance

1. **Header**– No maintenance required.
2. **Injection Tube**– No maintenance required.
3. **Water Seal** – Should be inspected periodically to make sure the traps are clear.

Non-Wetting Distance With a Insty-Pac Tube Assembly Having 3” Centers

Relative Humidity Leaving	90%	30"	15"	13"	11"	8"	7"	5.5"	2"	1"
	85%	15"	11"	10"	9"	7"	5"	4"	1"	
	80%	10"	8"	7"	6"	5"	3"	2"		
	70%	8"	6"	5"	4"	3"	1"			
	60%	6"	4"	3.5"	2.5"	0.75"				
	50%	4"	3"	2"	0.75"					
	40%	2"	1.5"	0.5"						
	30%	1"	0.5"							
	20%	0.25"								
	10%	20%	30%	40%	50%	60%	70%	80%	85%	
	Relative Humidity Entering									

Non-Wetting Distance With a Insty-Pac Tube Assembly Having 6” Centers

Relative Humidity Leaving	90%	60"	30"	27"	24"	20"	16"	14"	13"	9"
	85%	50"	24"	21"	17"	13"	12"	10"	8"	
	80%	40"	19"	15"	13"	9"	8"	7"		
	70%	30"	15"	11"	9"	6"	4"			
	60%	15"	11"	8"	5"	3"				
	50%	9"	8"	4"	2"					
	40%	5"	4"	1"						
	30%	2.5"	1"							
	20%	0.5"								
	10%	20%	30%	40%	50%	60%	70%	80%	85%	
	Relative Humidity Entering									

The above is based on air conditions of 55°F duct temperature at a velocity of 500 feet per minute. Dissipation distance may vary depending on airflow and temperature characteristics.

**Maximum Steam Supply Piping Capacities
(Atmospheric Applications Only)**

Type	lbs/hr (kg/hr)*	Type	lbs/hr (kg/hr)*	Type	lbs/hr (kg/hr)*
N/A		N/A		1 1/4" Schd'I 40 Pipe	130 (59)
1 1/2" Flexible Hose	150 (68)	1 1/2" Copper/ SST Tubing	130 (59)	1 1/2" Schd'I 40 Pipe	150 (68)
2" Flexible Hose	250 (113)	2" Copper/ SST Tubing	200 (68)	2" Schd'I 40 Pipe	215 (98)
3" Flexible Hose	500 (227)	3" Copper/ SST Tubing	411 (186)	N/A	
N/A		4" Copper/ SST Tubing	730 (331)	N/A	

* For lengths up to 10'

Insulating hard piping is not required but will reduce condensate loss by 90%.

Air Pressure Loss in Inches of Water Column

Air Velocity	3" Tube Spacing	6" Tube Spacing
500 fpm	.025	.015
750 fpm	.060	.020
1000 fpm	.085	.030
1250 fpm	.130	.043
1500 fpm	.180	.055

Note: Tube spacing greater than 6" has no measureable air pressure loss.



141 Jonathan Blvd. North
Chaska, MN 55318

Tel: (952) 368-9335 Fax: (952) 368-9338
www.purehumidifier.com